

Composition of Probe

TP400 cable probe consist of three pieces:
 1) TP400 trigger probe unit(with integrating interface);
 2) Two four-core, oil proof shielded cable, one of them is a spiral cable with aviation plugs at both ends. The total length of the two cables is 8 meters;
 3) Stylus(standard model: M4-P50-RB6-S36A).

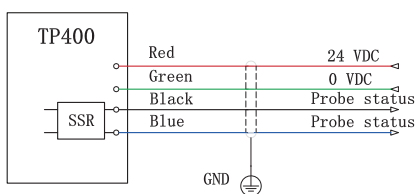
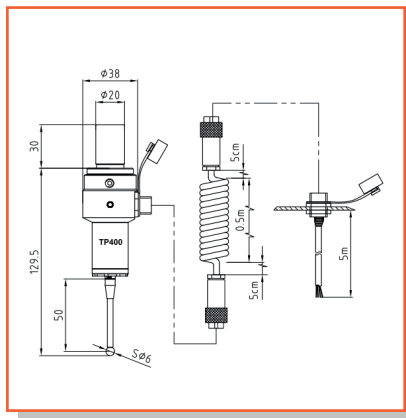

Application

- ◆ Setting work-piece coordinate system and machining zero points automatically before processing;
 - ◆ Detect and control the key dimensions, position coordinates and their precision automatically between two processes;
 - ◆ Detect precision of the key dimensions, shapes, position after processing.
- Applicable equipments:

Technical Parameters for probe and interface

- ◆ Stylus sensing direction: $\pm X, \pm Y, +Z$;
- ◆ Stylus sensing over-travel : $X-Y \pm 12^\circ, Z +5 \text{ mm}$;
- ◆ The trigger force in Z direction: 1000 g;
- ◆ Trigger force in X-Y surface (standard stylus) : 65-130g;
- ◆ Unidirectional repeatability (2σ) : $\leq 1 \mu\text{m}$;
- ◆ Input voltage is $24\text{V} \pm 10\%$ (DC) and output load current is 50 mA.
- ◆ Seal grade: IP68.

Technical Characteristics

- ◆ The signal interface of probe is integrated inside the probe, and the trigger signal is transmitted by cable;
- ◆ By changing the power supply's polarity at the probe interface, the logic state of the output signal can be reversed;
- ◆ The stylus connector of the probe is protected by double layers of rubber seal.
- ◆ The probe uses two pieces of cable to transmit signals, one of spiral cable has aviation plugs at both ends , which can be quickly installed and discounted, providing convenience for the application of the probe in different equipments.

Applicable equipment and conditions

- ◆ Various specifications of CNC grinding machines, CNC lathes and specially measuring devices.

Notes for purchase

- ◆ As for special stylus, check whether the standard stylus equipped with the TP400 probe can meet the requirements and whether it is necessary to order special stylus;
- ◆ About sealing protection of the connectors for stylus and probe: for TP400 probe applied in CNC lathe, it is recommended that the customer give protecting instruction to use metal cover + rubber sealing cover when ordering the probe.